

Solar Based Automatic Irrigation System

Binoy Seal, Omkar Shirke, Siddhesh Shewale, Abhilash Sirsikar, Prof. Priya Hankare

K.J. Somaiya Institute of Engineering & IT, Sion, Mumbai

Department of Electronics and Telecommunication

Mumbai University

Mumbai, India

Email id: b4.siddhesh.shewale@gmail.com, b4.omkar.shirke@gmail.com

Abstract: This paper deals with the design of solar tracking system to harness maximum solar energy that is converted into electrical energy which in turn is used to power the irrigation system. The designed single axis solar tracker device, on the basis of LDR sensor values, orients the PV panel in accordance with the position of the sun. The irrigation pump can be controlled in two modes namely

1. Automatic mode 2. GSM mode

In Automatic mode the water pump is switched on and off automatically based on moisture sensor value.

In GSM mode the farmer at his own discretion can send a message to ON and OFF the water pump without actually going to the field.

Index Terms— PV panel, irrigation system, LDR sensor, moisture sensor.

1. INTRODUCTION

The increasing demand for energy, the continuous reduction in existing sources of fossil fuels and the growing concern regarding environment pollution, have pushed mankind to explore new non-conventional, renewable energy resources such as solar energy, wind energy, etc for the production of electrical energy. Since India receives sunlight all 12 months of a year. Hence utilizing it in the different fields is a wise idea.

India is an agricultural country. India ranks second worldwide in farm output. At present, farmer manually irrigates land at regular interval. This process sometimes consumes more water or sometimes the water reaches late due to which the crops get dried. Solar powered automatic irrigation system not only overcomes this problem but also provide clean source of energy.

2. IMPLEMENTATION

2.1 Block Diagram

The proposed system is single axis solar tracker used for irrigation system along with GSM. The LDR placed on solar panel (12V, 5W) helps to track maximum intensity of sunlight and thus generate more electricity. The electricity produced is stored in battery (12V) which is further used to power the irrigation system. The analog values from LDR and moisture sensor are given to ADC0808 for its digital conversion. The digital values are taken as input by microcontroller 89s51 which is interfaced along with 12V DC pump, LCD and GSM module. With the use of GSM, farmer can switch on and off the pump at his own discretion just by sending a message.

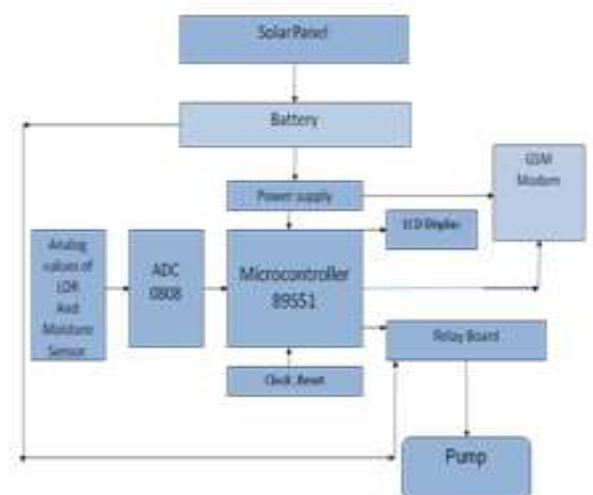

Fig 1. Block diag of present system

- (1) Solar panel: A solar panel is a set of solar photovoltaic modules electrically connected and mounted on a supporting structure. A photovoltaic module is a packaged, connected assembly of solar cells. The solar panel can be used as a component of a larger photovoltaic system to generate and supply electricity in commercial and residential applications. In the system we use 12V,5W solar panel.
- (2) Microcontroller89s51:The AT89S51 is a low-power, high-performance CMOS 8-bit

microcontroller with 4K bytes of In-System Programmable Flash memory. The AT89S51 provides the following standard features:

- (i) 4K bytes of Flash
 - (ii) 128 bytes of RAM,
 - (iii) 32 I/O lines,
 - (iv) Watchdog timer,
 - (v) two 16-bits timer/counters,
 - (vi) two-level interrupt architecture
 - (vii) a full duplex serial port
 - (viii) on-chip oscillator and clock circuitry
- (3) **ADC 0808:** The ADC 0808 data acquisition component is a monolithic CMOS device with an 8-bit analog to- digital converter, 8-channel multiplexer microprocessor compatible control logic. The 8bit A/D converter uses successive approximation as the conversion technique. The converter features a high impedance chopper stabilized comparator, a 256R voltage divider with analog switch tree and a successive approximation register. The 8- channel multiplexer can directly access any of 8-single-ended analog signals.
- (4) **GSM module:** It is a specialized type of modem which accepts a SIM card, and operates over a subscription to a mobile operator, just like a mobile phone. GSM networks operate in a number of different carrier frequency range, with most 2G GSM networks operating in the 900 MHz or 1800 MHz bands. A GSM modem exposes an interface to send and receive messages over the modem interface. The mobile operator charges for this message sending and receiving as if it was performed directly on a mobile phone. To perform these tasks, a GSM modem must support an “extended AT command set” for sending/receiving SMS messages.
- (5) **LCD:** It is a flat panel display, electronic visual display, or video display that uses the light modulating properties of liquid crystals..In our system we use 16X2 LCD.
- (6) **Motors:** This system uses the 12V DC permanent magnet motor for the single axis movement of solar panel.
- (7) **Sensors:** The LDR sensors are placed on the solar panel which helps in tracking maximum intensity of sunlight. Based on moisture sensor values the water pump is switched on and off automatically.

2.2 Prototype Design

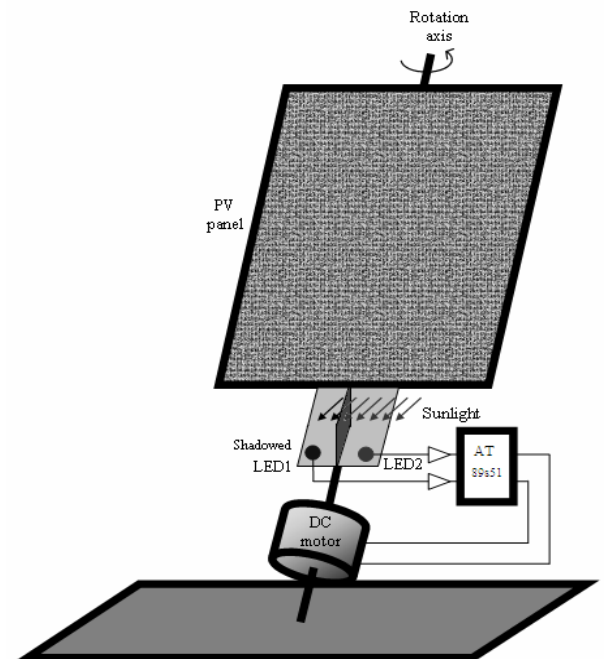

Fig 2. Principle of Solar Tracker



Fig 3. GSM Module

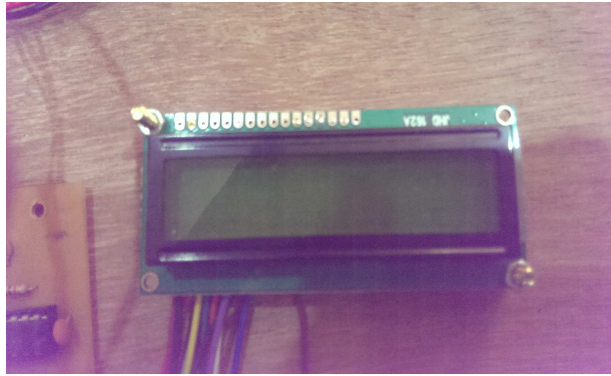

Fig 4. LCD Display

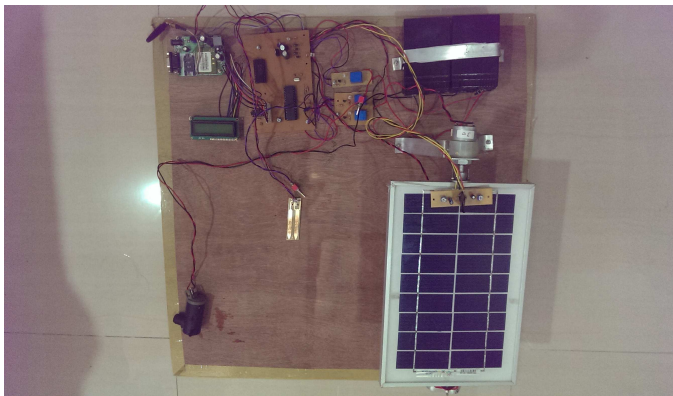
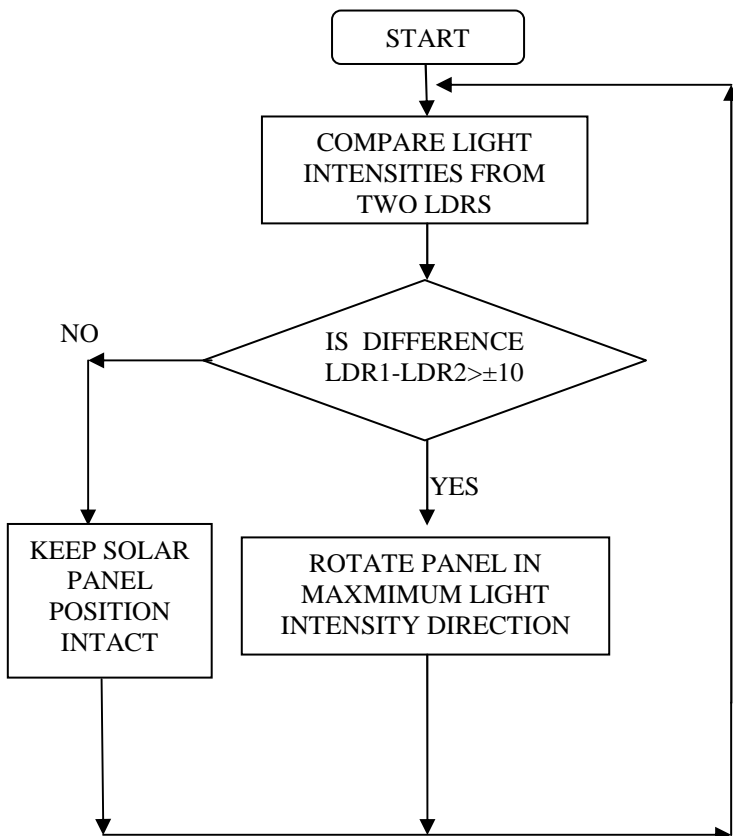

Fig 5. Prototype Design

2.3 Flow Chart

a. Flow Chart For Solar Tracking



b. Flow Chart For Irrigation System

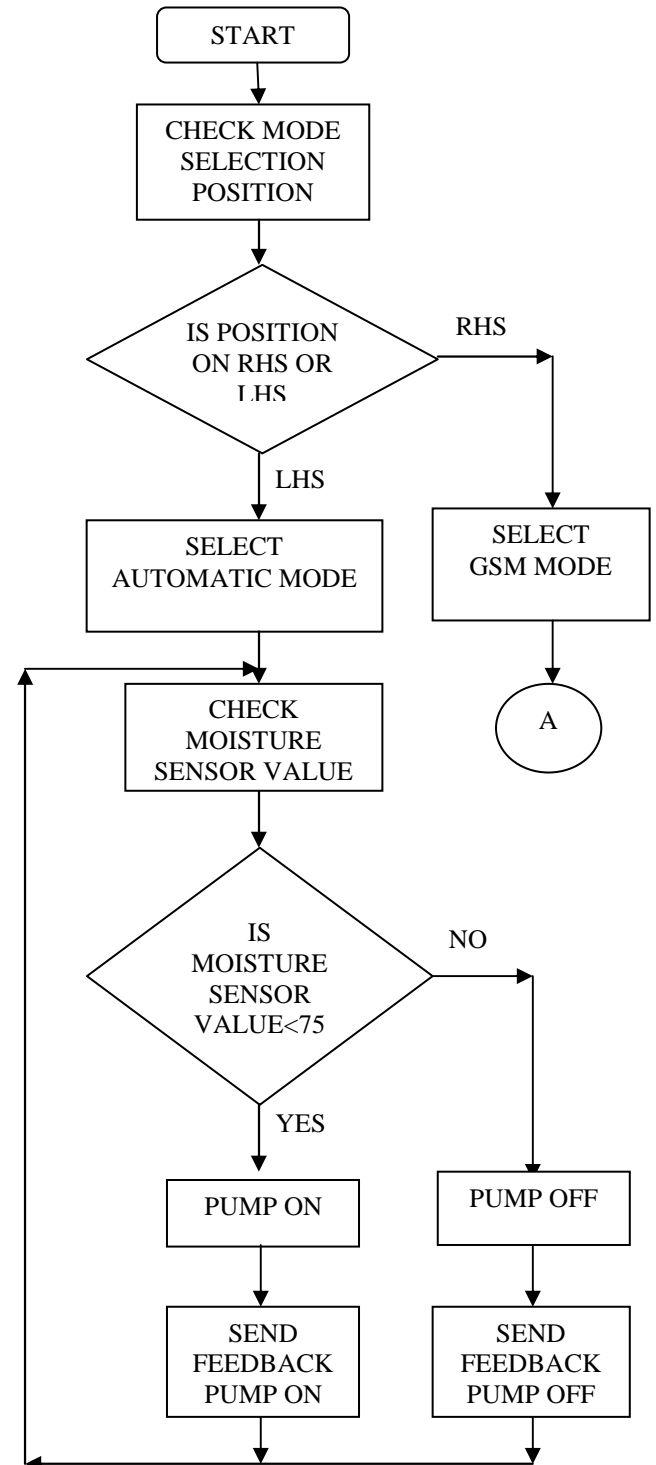

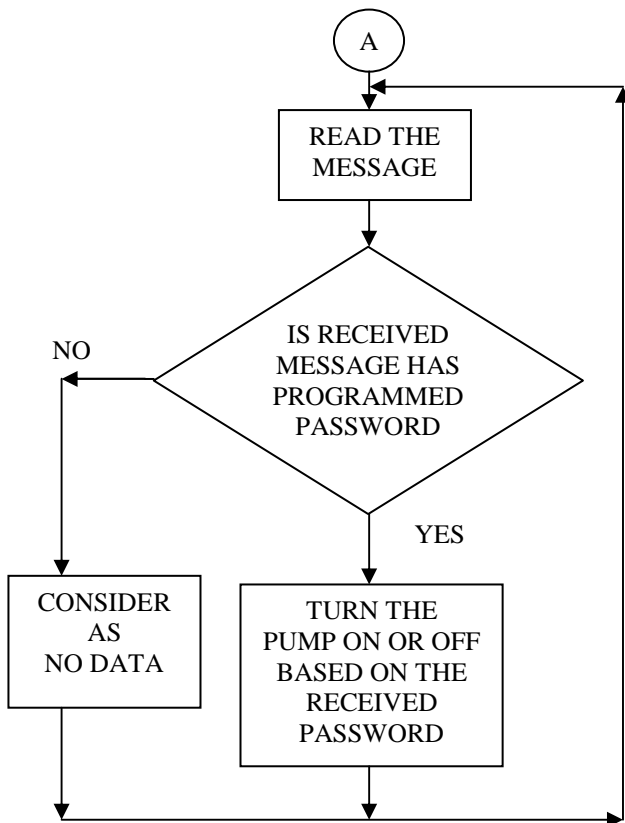

3. EXPERIMENTAL RESULT

- 1) If the difference between the two LDR sensors say S1 and S2 is greater than +10 ($S1-S2 > 10$) then solar panel will orient towards east direction and if is greater than -10 ($S1-S2 > -10$) solar panel will orient in west direction.
- 2) In automatic mode, if moisture sensor value goes below 75cbar than pump will be ON and once the exceeds 75cbar pump will be OFF automatically.
- 3) In GSM mode, after receiving message having programmed password, pump will be ON and feedback 'PUMP ON' is sent on the mobile number written in the program.
- 4) Similarly in GSM mode, after receiving message having programmed password, pump will be OFF and feedback 'PUMP OFF' is sent on the mobile number written in the program.

4. Advantage

Based on the obtained results we can conclude that the proposed solution for a solar tracking system offers several advantages concerning the movement of the PV panel:

- (1) a maximization of output energy produced by the PV panel, through an optimal positioning executed only for sufficient values of light signal intensity.
- (2) a guarantee of the panel positioning starting from any initial position of the PV panel.

- (3) the elimination of unnecessary movements, at too small intensities of the light signals or at too small differences between the signals received from the two LDR sensors.
- (4) The microcontroller makes system automatic and saves man power and as well as power & wastage of water.

5. CONCLUSION

The present proposal is a model to harness maximum available solar energy by tracking the sun and modernize the agriculture industries at a mass scale with optimum expenditure. The solar power irrigation system will help to reduce the gap between required and consumed energy and further conserves the resources thereby reducing the wastage of resource. This system can be improved by adding temperature sensors and dissolved solid sensors. To improve system internet can be used to control the system. GUI can be added to analyze the farm condition and sensors value graphically.

REFERENCE

- [1] Hemant Ingale and N.N.Kasat, Automated Solar Based Agriculture Pumping, vol. 2, Page no. 407-410.
- [2] Kassem A, Mosbeh Lebanon Hamad, MA Microcontroller-Based Solar Tracking System, Systems Conference(Syscon),2011 IEEE International Page no. 13-16.
- [3] Oka Bingo, Ahmed Altintas, Yousef Oner, A Microcontroller-Based Solar Tracking System and It's Implementation, Journal of Engineering Science, Page no 243-248.
- [4] Syed Arsalan, Sun Tracking System with Microcontroller 8051. International Journal of Scientific & Engineering Research, Volume 4, Issue 6, June-2013, Page no. 2998-3001.
- [5] Uddin, J, Automated Irrigation System Using Solar Power, Electrical and Computer (ICECE), 2012 7th International Conference, Page no. 228-231.
- [6] Yalla, S.P, Energy Management in an Automated Solar Powered Irrigation System, Information Communication and Embedded Systems (ICICES), 2013 International Conference, Page no. 1136-1140.
- [7] Mostefa Ghassoul, International Journal of Emerging Technology and Advanced Engineering, Volume 3, Issue 5, Page no. 453-460